



Product manual

PS Range - Single Phase Capacitor Vacuum Switches Installation, Operation and Maintenance Manual

Index

PS Range - Single Phase Capacitor Vacuum Switches

1.0	About this manual	3
2.0	Safety information	3
3.0	Packaging and transport.....	3
4.0	Acceptance	3
5.0	Storage and handling	4
6.0	Quality standards	4
7.0	Description of operation	4
7.1	Standards.....	5
7.2	Capacitor bank application	5
8.0	Technical data.....	6
9.0	Dimensions.....	8
10.0	Installation	10
10.1	Initial set-up.....	10
	Rating plate, Re-orient the insulator (if necessary).....	10
10.2	Mounting	10
10.3	High voltage connections	10
	Live and/or capacitor connections, Grounding.....	10
11.0	Control wiring and connections.....	11
11.1	Connection plug part numbers.....	12
11.2	Controlling / operating the switch.....	12
	48V DC control operation, Electrically held operation, Auxillary limit switch operation	13
12.0	Operation testing.....	14
12.1	Test procedure.....	14
12.2	Live operational procedure	15
13.0	Maintenance	15

1.0 About this manual

This manual relates to all single phase vacuum switches that make up the PS switch range manufactured by ABB. This includes all variants of the PS15, PS17 and PS25

2.0 Safety information

Ensure the installation, operation and maintenance is carried out by qualified personnel authorised to handle high voltage equipment.

Strictly follow the information in this instruction manual.

Check the rated performance of the apparatus is not exceeded during service.

Ensure the personnel operating the vacuum switch have this instruction manual.

Incorrect operation, handling or maintenance can result in death, severe personal injury and equipment damage.

Read and understand the contents of this instruction manual and follow all locally approved procedures and safety practices before installing, operating and maintaining this equipment.

Pay special attention to the safety issues represented by the following symbol



Pay special attention to the important notes represented by the following symbol



3.0 Packing and transport

The switch is packed in a double fluted heavy-duty cardboard box.

The switch is packed in the CLOSED position, however the switch may be shipped in open or closed position with no detrimental effect to the switch.

4.0 Acceptance

Every PS vacuum switch is fully assembled and tested at the ABB factory. It is in good condition when accepted by the carrier for shipment.

On receipt, inspect the switch thoroughly for damage and loss of parts incurred during shipping. Should any damage or loss be discovered, notify the shipping carrier immediately. Contact ABB for additional parts.

The contents inside of a shipped box include:

- One vacuum switch with nameplate corresponding to the unit ordered
- This instruction manual
- Two bird caps

PS Range - Single Phase Capacitor Vacuum Switches

5.0 Storage and handling

On receipt, the vacuum switch must be carefully unpacked and checked as described above, and then re-packed using the original material provided.

Store the vacuum switch in a dry, dust-free, non-corrosive area. Ensure the vacuum switch is positioned to minimise the risk of mechanical damage.

When handling, avoid any stress to the functional insulating parts and the terminal connections of the vacuum switch. The recommended method of handling the vacuum switch is from the base of the insulator body as shown below in figure 1.



Figure 1: Correct handling of the switch



HANDLE WITH CARE.
Failure to follow correct handling procedures could result in equipment damage.

6.0 Quality standards

ABB is certified to the following quality and environmental standards:

- ISO 9001:2000 (Quality)
- ISO 14001:2004 (Environmental)

7.0 Description of operation

The PS range of single phase switches are a solid dielectric, electrically operated vacuum switch suitable for use in distribution systems.

The switch utilizes ABB's proven vacuum technology that is specifically designed for switching capacitor loads. Its design incorporates a fast acting solenoid mechanism, which provides force-travel characteristics ideal for vacuum switching. The solenoid mechanism also reduces the number of parts in the design and the frequency of maintenance.

The vacuum switches have an insulator made of advanced 'hydrophobic cycloalaphatic epoxy' (HCEP) resin. The insulator is chip and crack resistant, and has insulating properties similar to silicones. This leads to less surface wetting, providing better reliability and improved life expectancy. It is also resistant to ultraviolet light and its high creepage characteristics ensure suitability in highly contaminated environments.

Each vacuum switch consists of:

- A single pole vacuum switch with mechanical latching (separate open and close signals required for operation) or electrically latching (only close signal required, switch trips when close signal is removed), depending on model ordered.
- A mechanical position indicator signalling OPEN / CLOSED and acting as a lever to manually trip the switch.
- Various types of control voltages.
- Auxiliary limit switch contacts (for switch position indication).

7.1 Standards

The PS vacuum switches comply with the following standards:

- ANSI C37.66 (1969)
- Class 2 restrike rating (in accordance with IEEE 37.66)

7.2 Capacitor bank application



DANGER HIGH VOLTAGE!
The application engineering of the PS15 or PS25 vacuum switch should only be performed by authorised personnel.

The switch is suitable for a variety of applications including pole mounted capacitor banks and metal-enclosed capacitor banks. It is an outdoor device, which can also be applied to indoor solutions.

In application, it is highly recommended that the vacuum switch is protected under short-circuit conditions. Fuses and circuit breakers are typically used. For example, in pole mounted capacitor banks, expulsion 'drop-out' fuses are typically connected upstream as means of protection. Figures 2 and 3 show a typical layout of a pole mounted capacitor bank with associated connection diagram.

The type test certificate from an independent laboratory is available from upon request.

The vacuum switches can be switched using a variety of controls. Manual control (ie. electrical push buttons) is the most basic form. Automatic controls using time, temperature, voltage, current, VAR, power factor or a combination of the above can also be used. The switches need a control signal lasting only 200 milliseconds to activate the solenoid mechanism and OPEN / CLOSE the switch.

ABB can provide the complete polemount solution through integration of its range of outdoor products. ABB's product range also includes, but is not limited to power capacitors, controllers, control voltage transformers, surge arrestors and fuse cut-outs. Please contact ABB for further information on related products and solutions.

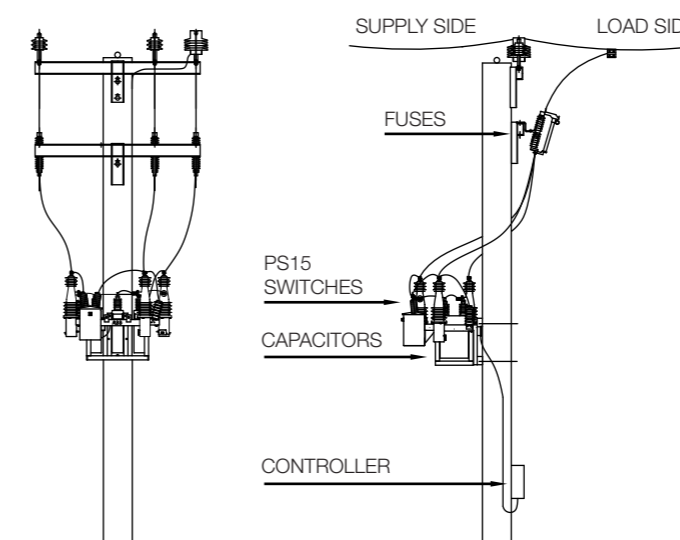

Figure 2: Typical pole mounted capacitor bank installation

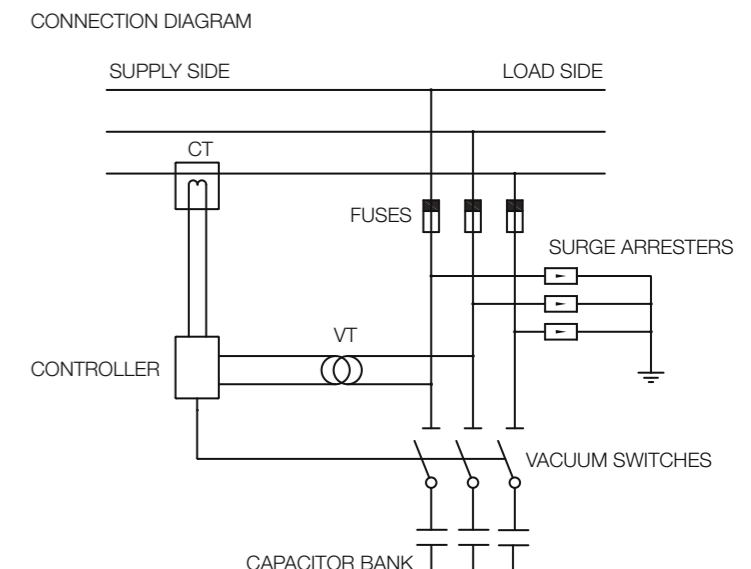

Figure 3: Typical polemount bank connection diagram

PS Range - Single Phase Capacitor Vacuum Switches

8.0 Technical data



Check the ratings of the switch prior to installation and operation.
Ensure the vacuum switch is applied within its specified ratings. Check the compatibility of the rating plate information with system characteristics prior to installation.

Electrical						
Switch type		PS15	PS17	PS25		
Rated maximum voltage						
Ungrounded capacitor banks, line-to-line	kV rms	15.5	17.5	25		
Grounded capacitor banks, line-to-line	kV rms	27	30	43		
Lightning impulse withstand voltage						
Line to ground	kV BIL	125	125	150	125	150
Open contact	kV BIL	95	125	125	125	125
Power frequency withstand voltage, 60Hz						
Dry, 1.0 minutes	kV	60	60	60		
Wet, 10 seconds	kV	50	50	50		
Continuous current 50/60Hz	A	200	400	400	200	
Capacitive switching current	A	200	400	400	200	
Symmetrical fault making current	A	6,000	6,000	6,000	6,000	
Short time withstand current						
1.0 second (symmetrical)	A	12,500	12,500	12,500	12,500	
High frequency making current						
Transient peak	A	12,000	12,000	12,000	12,000	
Transient in-rush frequency	Hz	6,000	6,000	6,000	6,000	
Control voltage range						
48V DC	VDC	36...60	36...60	36...60	36...60	
120V AC (50/60Hz)	VAC	90...130	90...130	90...130	90...130	
120V DC	VDC	90...130	90...130	90...130	90...130	
240V AC (50/60 Hz)	VAC	205...265	205...265	205...265	205...265	
Nominal current draw (during switching)						
120/240 VAC/DC (close/open)	A	10/5	10/5	10/5	10/5	
48 VDC (close/open)	A	25/10	25/10	25/10	25/10	
Nominal holding current	mA	100	100	100	100	
– electrically latched only						
Nominal open/close time	msec	100	100	100	100	
Min pulse length, 1.0 sec						
Creepage distance						
Terminal to terminal	mm	518	805	518	805	
	inch	20.4	31.7	20.4	31.7	
Terminal to ground	mm	510	770	510	770	
	inch	20.1	30.3	20.1	30.3	

General					
Switch type	Phase	PS15	PS17	PS25	
Weight	kg	13	16	13	16
	lbs	28	35	28	35
Operating temperature range	°C	-40 to +65	-40 to +65	-40 to +65	-40 to +65
	°F	-40 to +149	-40 to +149	-40 to +149	-40 to +149
Mechanical endurance		50,000+	50,000+	50,000+	50,000+
- close-open operations					
Control wiring requirements					
Number of pins		5 or 7	5 or 7	5 or 7	5 or 7
Wire size	mm ²	1.5 to 2.5	1.5 to 2.5	1.5 to 2.5	1.5 to 2.5

Type test certificates from independent testing facilities are available upon request.

Accessories / options	
Capacitor Bank Controller – ABB CQ900L (local) and CQ900R (remote)	Junction box
Connection cables (including connectors)	Remote / Low Power Pack supplies

PS Range - Single Phase Capacitor Vacuum Switches

9.0 Dimensions

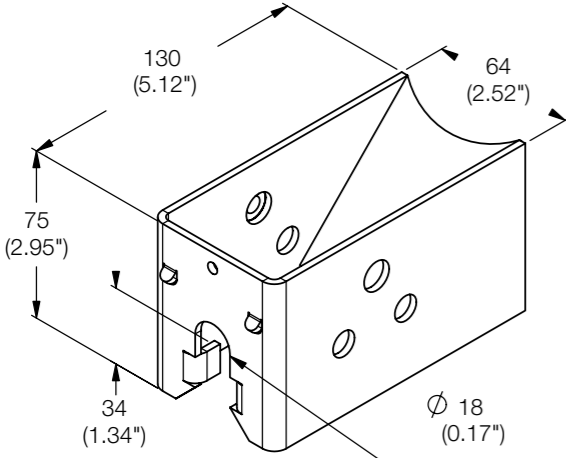

MOUNTING BRACKET

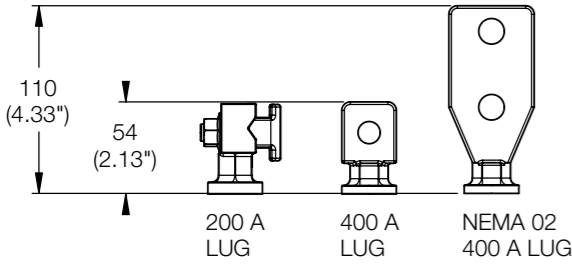

LUG OPTIONS

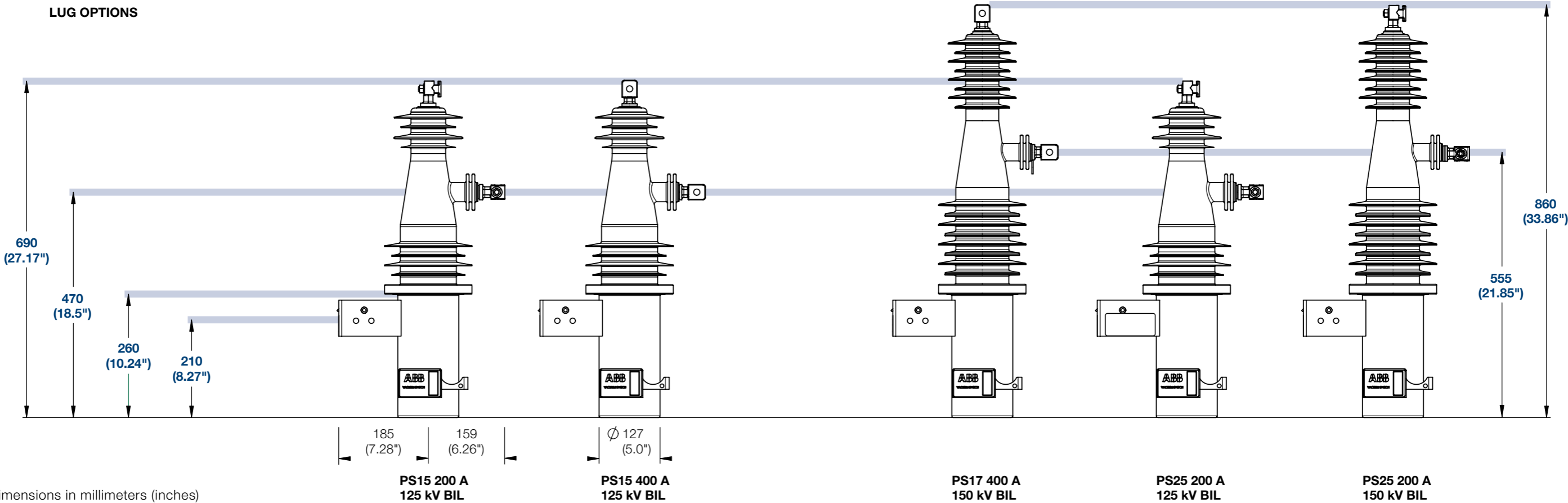
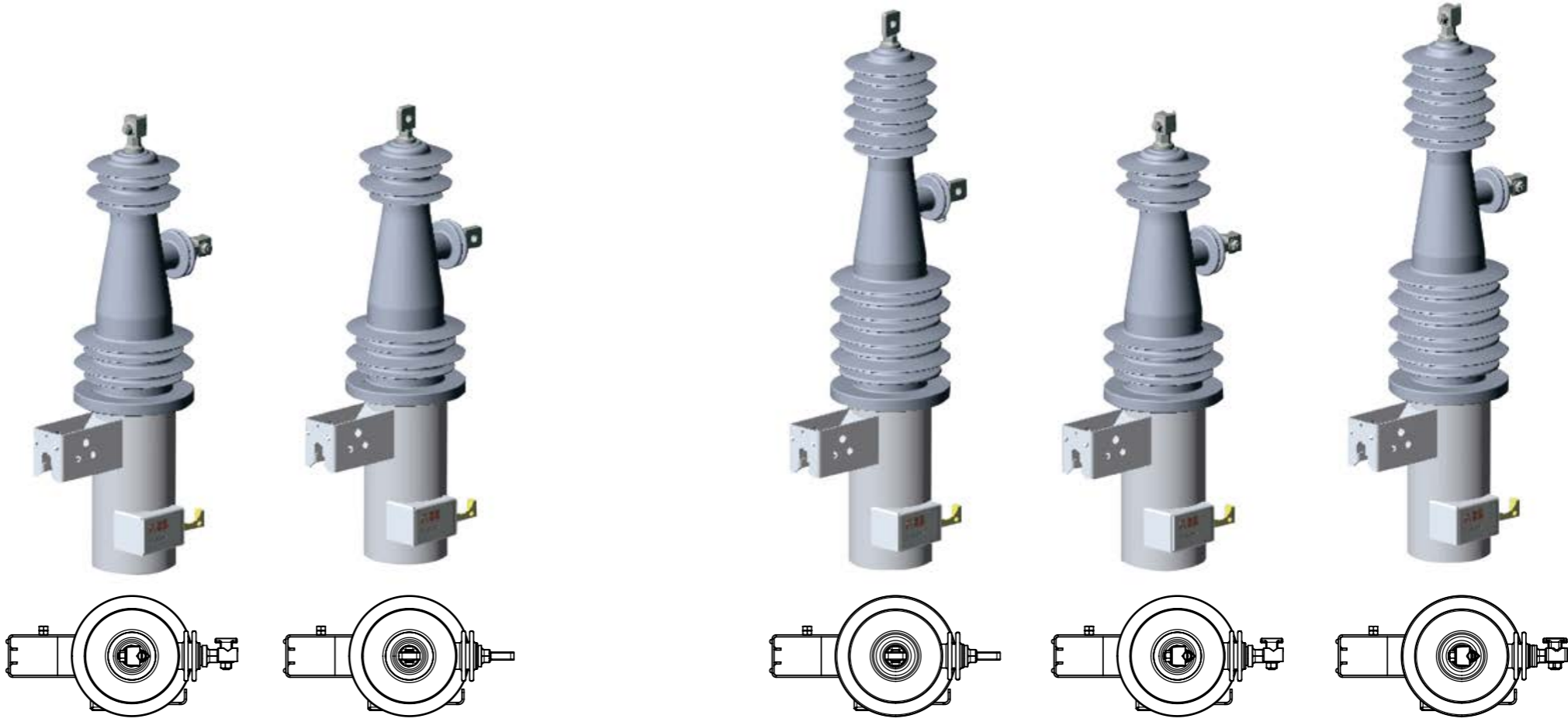

**PS15 200 A
125 kV BIL**

**PS15 400 A
125 kV BIL**

**PS17 400 A
150 kV BIL**

**PS25 200 A
125 kV BIL
(Low Profile)**

**PS25 200 A
150 kV BIL**

Note: All dimensions in millimeters (inches)

10.0 Installation



DANGER HIGH VOLTAGE!

Only trained personnel authorised to handle high voltage equipment must carry out installation of PS switches.

10.1 Initial set-up

Rating plate

Check the rating plate to ensure the vacuum switch is suitable for the installation conditions.

Re-orient the insulator (if necessary)

The insulator body can be rotated relative to the tank housing to ease high voltage line and/or capacitor connections. To rotate the housing, loosen the four insulator-to-tank mounting bolts three complete turns,

and lift and rotate the insulator body to suit the installation. One of the four mounting bolts (the "locating" bolt) has an extended bolt head that will prevent the housing turning more than 170 degrees each way. **DO NOT COMPLETELY REMOVE THE LOCATING BOLT.** This is to prevent over-rotation which can pull the internal wiring out. After re-orienting the terminals, immediately re-torque the insulator-to-tank mounting bolts in an alternating pattern to 13 Nm (10 lb-ft).



Failure to tighten insulator-to-tank mounting fasteners can result in equipment damage.

10.2 Mounting

The switch has a mounting bracket suitable for direct bolting to a wooden pole or a galvanized frame using M16 (5/8" diameter), galvanized fasteners. The mounting fasteners are not included. Refer to section 9 - Dimensions for details of the mounting bracket.



Ensure the mounting arrangement does not reduce the required insulation level of the switch or adjacent equipment.

10.3 High voltage connections

Line and/or capacitor connections

Connect the primary cables to the switch terminals. The universal clamp-type terminals accommodate AWG No. 8 solid through 2/0 AWG stranded or up to 70mm² conductor.

Tighten the terminal clamps using a torque wrench to 13-20 Nm (10-15 lb-ft). Ensure proper work practices are utilized when tightening the connection to eliminate any stress on the switch terminal.

Also available are single hole and double hole (NEMA type) terminals for terminating cable fitted with lugs up to M12 (1/2"). These terminals are optional on all switch types, but are primarily designed for use on 400A rated switches.

The arrangement of high voltage cables should not reduce the required insulation level of the switch or adjacent equipment.

Undue stress can damage the integrity of the terminal connector.

Grounding

Make sure the switch housing is solidly grounded using the ground terminal (or bolt) located on the mounting bracket. See figure 3a. Failure to adequately ground the switch housing can cause damage to the electronic components inside the switch housing, and result in switch failure.



The customer is responsible for grounding the switch in a safe manner and in accordance with all applicable standards.



If an ungrounded capacitor bank is specified, special consideration must be given to the connection of the switches. ABB recommends that the switches be mounted on suitable insulators to prevent damage due to the potentially energized rack. Please consult ABB if using ungrounded capacitor banks



Solidly ground all equipment. Failure to achieve an effective ground connection can result in death or severe personal injury. Check all connections. Loose connections create high resistance 'hot-spots'.

11.0 Control wiring and connections

Control of the PS switch is made through a standard MIL-Spec style male plug located on the lower tank inside the mounting bracket. Depending on the model number selected the plug will either be a 5-pin or 7-pin receptacle. The orientation is detailed below in figures 3a, b and c.

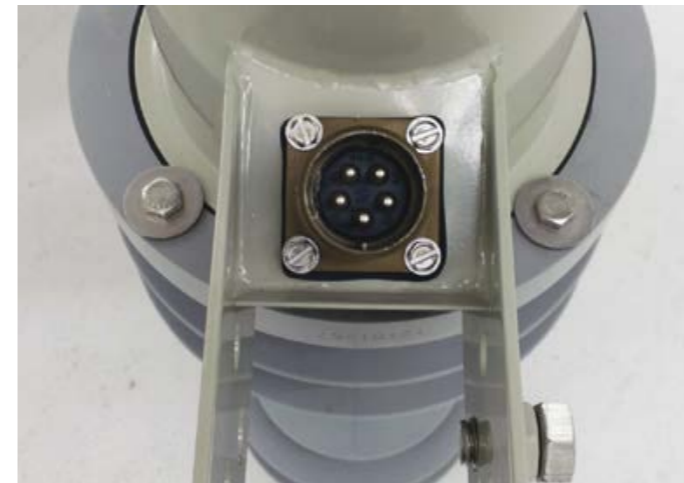

Figure 3a: View of male socket from bottom of switch and earthing bolt

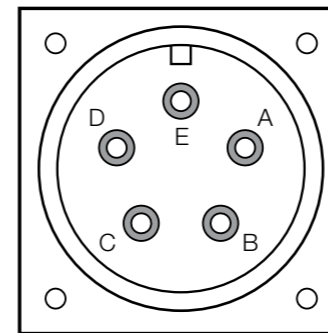

Figure 3b: 5-pin male socket

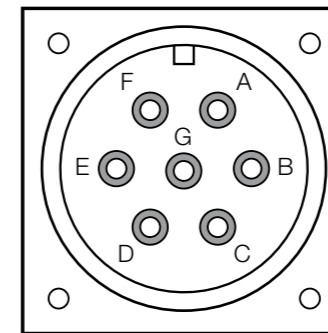

Figure 3c: 7-pin male socket

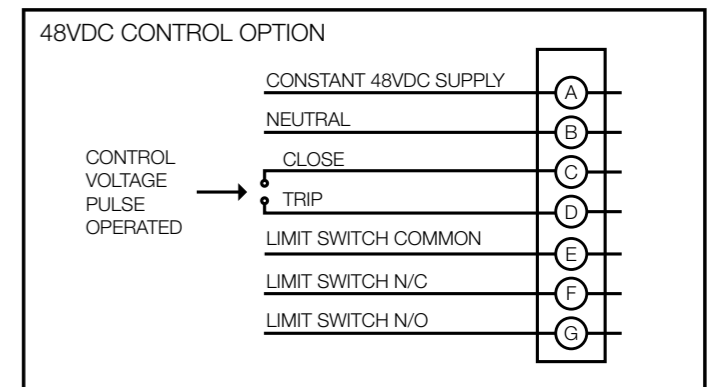
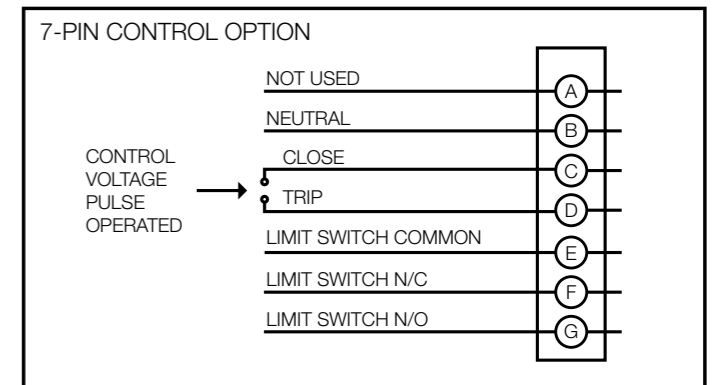
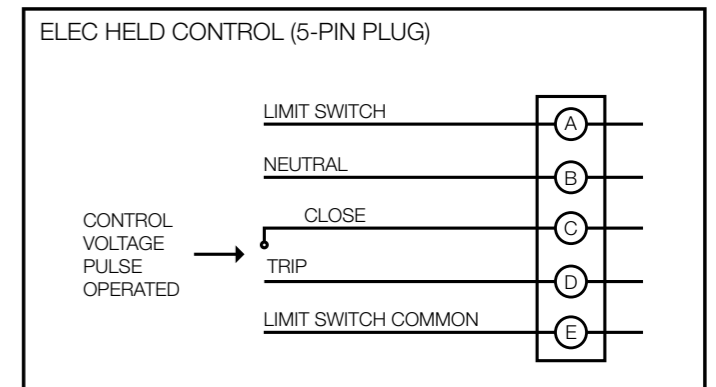
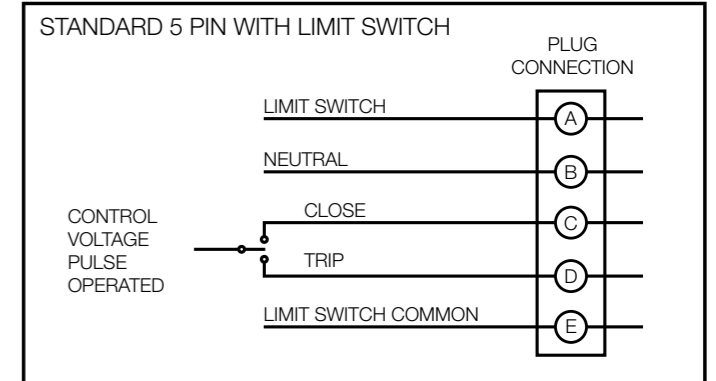

Figure 4: Control signal pin assignments

PS Range - Single Phase Capacitor Vacuum Switches

11.1 Connection plug part numbers

	Part number (Amphenol)
5 pin male plug on switch	MS 3102R 18-11P
5 pin female cable plug	MS 3106F-18-11S
7 pin male plug on switch	MS 3102R 16S-1P
7 pin female cable plug	MS 3106F-16F-1S

11.2 Controlling / operating the switch

To operate a PS switch a control signal of at least 200 milliseconds must be applied for each OPEN and CLOSE operation. Signals shall be supplied between the active pin (open or close) and the neutral pin. To allow for possible delays in support equipment operation and to ensure no misoperation occurs it is recommended that the signal be kept on for at least 1 second. The electronics inside the switch ensure power is only drawn for the time required to actuate the switch. Leaving the control signal permanently on to the switch (latched signal) has no detrimental effect on switch operation. The pin assignment for various PS switch models is given in Figure 4.

A manual or automatic controller is recommended to operate PS vacuum switches. Automatic controllers measure the parameters of the electrical system and actuate the switches based on pre-programmed settings. eg voltage, time schedule, temperature, VAR. The controller switch contacts should have a transient inrush rating of greater than 10A per switch. For a controller that operates three switches simultaneously a "Slow Blow" 10 to 12 amp switch fuse is recommended.

The ABB CQ900 series capacitor controller is ideal for control of the PS series vacuum switches. The CQ900L is a standalone automatic smart controller while the CQ900R is a fully featured remote controllable device utilizing DNP3.0 as the communications protocol. Other features include a 4-line LCD screen, user friendly interface, neutral current sensing, ABB CapLink short range wireless comms, and intuitive programming software. Please contact your ABB representative for more information.



Due to the current draw from each switch during the OPEN / CLOSE operation (up to 10A), it is recommended that no more than three switches be actuated simultaneously on the same supply. It is recommended that a VT no smaller than 1.5KVA be used for controlling 3 switches (particularly for polemount operation). Using an undersized power supply can cause an instantaneous voltage drop during switching and prevent the switch from completing its operation. Continued operation under this condition can damage the switch's control circuit board leading to switch failure. Please contact ABB for more information if unsure.

48V DC control operation

As seen in Figure 4, the 48VDC controlled switch utilises Pin A as a constant control power supply. This reduces the need for the control circuit (open and close signals) to carry the high current signal required to operate the switch. The advantage of this is that longer distances can be employed from the control source to the switch without affecting the switch operation due to voltage drops. It is recommended that the power supply source be mounted as close to the switches as possible.

To drive the 48V DC switches requires a power supply that can supply instantaneous power / high momentary outrush current (100ms max) to the switches. ABB recommends the use of a locally mounted capacitor discharge power supply as an inexpensive alternative to directly supplying the units from a high output battery type supply. This can be installed per switch or per set of three single phase switches. Please contact ABB for details.

Electrically held operation

Electrically held switches utilise the same wiring configuration as the standard 5-pin or 7-pin switches. The main point of difference is that only the CLOSE signal is required, and that the signal must be continuously supplied (latched signal, not pulsed). As soon as control power is removed from the close pin, the switch will automatically trip open – no trip signal required.

Auxiliary limit switch operation

Each PS switch is fitted with an internal limit switch to indicate the position of the switch HV contacts. The limit switch provides volt-free contacts which can be connected to a relay or control system to monitor the operation of the switch remotely. The standard 5-pin plug allows either a normally open (N/O) or normally closed (N/C) signal output based on when the switch is open, while the standard 7-pin plug brings out both N/O and N/C signals. The limit switch contacts are rated for 0.5A (at 260VAC) continuous.



It is not mandatory that the Pin A power supply be used. If the control circuit can handle the high current required, the switch can be wired as per the standard 7-pin switch. If capacitor discharge power supplies are being used, a constant power supply must be available to keep the capacitors charged.



As the internal limit switch is controlled by the movement of the DC solenoid within the switch. If the switch is damaged (due to excess wear, external physical force, welding of the HV contacts etc.) the limit switch may not give a true indication of the position of the HV contacts inside the vacuum interrupter. The limit switch output should not be used as the sole indication of the status of the switch especially where live voltages and personnel are involved. Proper isolation and earthing procedures should always be used where live equipment is concerned.

PS Range - Single Phase Capacitor Vacuum Switches

12.0 Operation testing

 **DANGER HIGH VOLTAGE!**
Ensure authorised personnel perform the operation of high voltage equipment. Failure to execute safe work practices can result in death, severe personal injury and equipment damage.

After installation, check that the vacuum switch is:

- Mechanically secure
- Electrical connections are tight
- Electrical clearances are maintained to suit the required insulation level

12.1 Test procedure

Test the switching operation without connection to the high voltage line using either an automatic control device or manual test box. Upstream protection (eg. fuses) should be disconnected and/or removed to execute the test procedure.

The switch can only be closed using a control signal. When closed the visible edge of the position indicator will be parallel with the base of the tank. See figure 5a. When tripped or open the visible edge of the indicator lever will be at approx 30 degrees to the housing base. See figure 5b.

The switch can be manually opened by pushing down on the manual trip lever (also the position indicator). If installed on a pole mounted bank, a hook-stick can be used to do this. The manual trip lever should require approx 10kg (22lb) of force to open.

 **The trip lever can only be used to open the switch. The switches internal mechanisms will not allow the switch to be closed manually using the indicator lever. Trying to force the switch to close this way can result in damage to the switch.**

The switch requires a downward force of approximately 10kg (22lb) to operate the trip lever. Excessive force can pull the indicator lever out of its locating mechanism resulting in non-indication of switch operations. It can also stress or damage the lever, reducing its operational life.

Where possible, it is better to utilise the control circuit to operate the switch.

12.2 Live operational procedure

 **The capacitor bank requires several minutes to discharge prior to, and between successive operations. If the waiting time is not specified on the capacitor unit rating plate, contact the manufacturer. Standard discharge levels are 50V in 5 minutes (AS and IEEE) or 75V in 10 minutes (IEC)**

Energise the high voltage line. Most commonly this involves connecting in the overhead fuses

Energise the control circuit, if separate. Operate the control circuit to CLOSE the switch. The visible edge of the position indicator will be parallel with the base of the tank

Operate the control circuit to OPEN the switch. The visible edge of the position indicator lever will be at approx 30 degrees to the housing base.

13.0 Maintenance

 **DANGER HIGH VOLTAGE!**
Ensure authorised personnel perform the maintenance of high voltage equipment. Failure to execute safe work practices can result in death, severe personal injury and equipment damage.

The PS vacuum switches have been designed with a mechanical life of over 50,000 close-open operations without the need for routine maintenance. The switches do however require routine inspection to check for physical damage and to verify their operation.

The frequency of inspection depends on the service conditions. The switches are designed for widely varying applications and climatic conditions and thus service intervals are best determined by the customer based on site conditions and operating experience.



Figure 5a: CLOSED switch



Figure 5b: OPEN switch using hook stick

Contact us

For further information please contact:

ABB Australia Pty Limited

88 Beresford Road

Lilydale Vic 3140 Australia

Phone +61 (0) 3 9735 7333

Fax +61 (0) 3 9735 3863

www.abbaustralia.com

Note

While care has been taken to ensure that the information contained in this document is correct, no responsibility can be accepted for any inaccuracy.

We reserve the right to alter or modify the information contained herein at any time in the light of technical or other developments. Technical specifications are valid under normal operating conditions only.

We do not accept any responsibility for any misuse of the product and cannot be held liable for indirect or consequential damages. Technical data and design can be subject to change and should be confirmed prior to ordering.